

# **USB HID SWIPE READER TECHNICAL REFERENCE MANUAL**

**Manual Part Number 99875191 Rev 9**

**NOVEMBER 2005**

**MAGTEK<sup>®</sup>**

**REGISTERED TO ISO 9001:2000**

20725 South Annalee Avenue

Carson, CA 90746

Phone: (310) 631-8602

FAX: (310) 631-3956

Technical Support: (651) 415-6800

*[www.magtek.com](http://www.magtek.com)*

Information in this document is subject to change without notice. No part of this document may be reproduced or transmitted in any form or by any means, electronic or mechanical, for any purpose, without the express written permission of MagTek, Inc.

MagTek is a registered trademark of MagTek, Inc.

USB (Universal Serial Bus) Specification is Copyright© 1998 by Compaq Computer Corporation, Intel Corporation, Microsoft Corporation, NEC Corporation.

### REVISIONS

Rev Number	Date	Notes
1	15 Jun 01	Initial Release
2	22 Jun 01	Section 4. On Tracks 1, 2, and 3 Decode Status delete "more than eight bits of data" and add "data on it that is not noise." From Card Encode Type, Value 3, delete "This device does not detect blank cards so this value will never occur."
3	25 Jul 01	Front Matter: Agency Approvals: Corrected Class B for CE.
4	17 Aug 01	Section 4, Report Descriptor: Changed Logical Maximum from 25 ff to 26 ff 00.
5	12 Dec 02	Section 4, Command Number: Corrected GET and SET PROPERTY descriptions.
6	28 Jan 03	Changed copyright symbol so pdf copies would print on all printers
7	03 Jun 03	Front Matter: added ISO line to logo, changed Tech Support phone number, added new warranty statement.
8	17 May 05	Included references to new commands added after June 2005. Sec 4: Replaced all of Section 4.
9	22 Nov 05	Sec 1: To Hardware Configuration Table, added P/N 21040139. Corrected cable descriptions for Models 21040119 and 21040139.

## **LIMITED WARRANTY**

MagTek warrants that the products sold to Reseller pursuant to this Agreement will perform in accordance with MagTek's published specifications. This warranty shall be provided only for a period of one year from the date of the shipment of the product from MagTek (the "Warranty Period"). This warranty shall apply only to the original purchaser unless the buyer is authorized by MagTek to resell the products, in which event, this warranty shall apply only to the first repurchase.

During the Warranty Period, should this product fail to conform to MagTek's specifications, MagTek will, at its option, repair or replace this product at no additional charge except as set forth below. Repair parts and replacement products will be furnished on an exchange basis and will be either reconditioned or new. All replaced parts and products become the property of MagTek. This limited warranty does not include service to repair damage to the product resulting from accident, disaster, unreasonable use, misuse, abuse, customer's negligence, Reseller's negligence, or non-MagTek modification of the product. MagTek reserves the right to examine the alleged defective goods to determine whether the warranty is applicable.

Without limiting the generality of the foregoing, MagTek specifically disclaims any liability or warranty for goods resold in other than MagTek's original packages, and for goods modified, altered, or treated by customers.

Service may be obtained by delivering the product during the warranty period to MagTek (20801 S. Annalee Ave., Carson, CA 90746). If this product is delivered by mail or by an equivalent shipping carrier, the customer agrees to insure the product or assume the risk of loss or damage in transit, to prepay shipping charges to the warranty service location and to use the original shipping container or equivalent. MagTek will return the product, prepaid, via a three (3) day shipping service. A Return Material Authorization (RMA) number must accompany all returns.

**MAGTEK MAKES NO OTHER WARRANTY, EXPRESS OR IMPLIED, AND MAGTEK DISCLAIMS ANY WARRANTY OF ANY OTHER KIND, INCLUDING ANY WARRANTY OF MERCHANTABILITY OR FITNESS FOR A PARTICULAR PURPOSE.**

**EACH PURCHASER UNDERSTANDS THAT THE MAGTEK PRODUCT IS OFFERED AS IS. IF THIS PRODUCT DOES NOT CONFORM TO MAGTEK'S SPECIFICATIONS, THE SOLE REMEDY SHALL BE REPAIR OR REPLACEMENT AS PROVIDED ABOVE. MAGTEK'S LIABILITY, IF ANY, TO RESELLER OR TO RESELLER'S CUSTOMERS, SHALL IN NO EVENT EXCEED THE TOTAL AMOUNT PAID TO MAGTEK BY RESELLER UNDER THIS AGREEMENT. IN NO EVENT WILL MAGTEK BE LIABLE TO THE RESELLER OR THE RESELLER'S CUSTOMER FOR ANY DAMAGES, INCLUDING ANY LOST PROFITS, LOST SAVINGS OR OTHER INCIDENTAL OR CONSEQUENTIAL DAMAGES ARISING OUT OF THE USE OF OR INABILITY TO USE SUCH PRODUCT, EVEN IF MAGTEK HAS BEEN ADVISED OF THE POSSIBILITY OF SUCH DAMAGES, OR FOR ANY CLAIM BY ANY OTHER PARTY.**

### **LIMITATION ON LIABILITY**

**EXCEPT AS PROVIDED IN THE SECTIONS RELATING TO MAGTEK'S LIMITED WARRANTY, MAGTEK'S LIABILITY UNDER THIS AGREEMENT IS LIMITED TO THE CONTRACT PRICE OF THE PRODUCTS.**

**MAGTEK MAKES NO OTHER WARRANTIES WITH RESPECT TO THE PRODUCTS, EXPRESSED OR IMPLIED, EXCEPT AS MAY BE STATED IN THIS AGREEMENT, AND MAGTEK DISCLAIMS ANY IMPLIED WARRANTY, INCLUDING WITHOUT LIMITATION ANY IMPLIED WARRANTY OF MERCHANTABILITY OR FITNESS FOR A PARTICULAR PURPOSE.**

**MAGTEK SHALL NOT BE LIABLE FOR CONTINGENT, INCIDENTAL, OR CONSEQUENTIAL DAMAGES TO PERSONS OR PROPERTY. MAGTEK FURTHER LIMITS ITS LIABILITY OF ANY KIND WITH RESPECT TO THE PRODUCTS, INCLUDING ANY NEGLIGENCE ON ITS PART, TO THE CONTRACT PRICE FOR THE GOODS.**

**MAGTEK'S SOLE LIABILITY AND BUYER'S EXCLUSIVE REMEDIES ARE STATED IN THIS SECTION AND IN THE SECTION RELATING TO MAGTEK'S LIMITED WARRANTY.**

## **FCC WARNING STATEMENT**

This equipment has been tested and found to comply with the limits for Class B digital device, pursuant to Part 15 of FCC Rules. These limits are designed to provide reasonable protection against harmful interference when the equipment is operated in a residential environment. This equipment generates, uses, and can radiate radio frequency energy and, if not installed and used in accordance with the instruction manual, may cause harmful interference to radio communications. However, there is no guarantee that interference will not occur in a particular installation.

## **FCC COMPLIANCE STATEMENT**

This device complies with Part 15 of the FCC Rules. Operation of this device is subject to the following two conditions: (1) This device may not cause harmful interference; and (2) this device must accept any interference received, including interference that may cause undesired operation.

## **CANADIAN DOC STATEMENT**

This digital apparatus does not exceed the Class B limits for radio noise for digital apparatus set out in the Radio Interference Regulations of the Canadian Department of Communications.

Le présent appareil numérique n'émet pas de bruits radioélectriques dépassant les limites applicables aux appareils numériques de la classe B prescrites dans le Règlement sur le brouillage radioélectrique édicté par le ministère des Communications du Canada.

## **CE STANDARDS**

Testing for compliance to CE requirements was performed by an independent laboratory. The unit under test was found compliant to Class B.

## **UL/CSA**

This product is recognized per Underwriter Laboratories and Canadian Underwriter Laboratories 1950.

## TABLE OF CONTENTS

<b>SECTION 1. FEATURES AND SPECIFICATIONS</b> .....	<b>1</b>
FEATURES.....	1
HARDWARE CONFIGURATIONS .....	2
ACCESSORIES.....	2
REFERENCE DOCUMENTS.....	3
SPECIFICATIONS.....	3
<b>SECTION 2. INSTALLATION</b> .....	<b>5</b>
USB CONNECTION .....	5
WINDOWS PLUG AND PLAY SETUP.....	6
MOUNTING.....	6
<b>SECTION 3. OPERATION</b> .....	<b>9</b>
LED INDICATOR .....	9
CARD READ.....	9
<b>SECTION 4. USB COMMUNICATIONS</b> .....	<b>11</b>
HID USAGES.....	11
REPORT DESCRIPTOR .....	12
CARD DATA .....	13
TRACK 1 DECODE STATUS .....	13
TRACK 2 DECODE STATUS .....	14
TRACK 3 DECODE STATUS .....	14
TRACK 1 DATA LENGTH.....	14
TRACK 2 DATA LENGTH.....	14
TRACK 3 DATA LENGTH.....	14
CARD ENCODE TYPE .....	15
TRACK DATA .....	15
TRACK 1 DATA .....	15
TRACK 2 DATA .....	15
TRACK 3 DATA .....	15
COMMANDS.....	16
COMMAND NUMBER .....	16
DATA LENGTH.....	16
DATA.....	16
RESULT CODE.....	17
GET AND SET PROPERTY COMMANDS.....	17
SOFTWARE_ID PROPERTY .....	18
SERIAL_NUM PROPERTY .....	19
POLLING_INTERVAL PROPERTY.....	20
MAX_PACKET_SIZE PROPERTY.....	21
TRACK_ID_ENABLE PROPERTY .....	22
INTERFACE_TYPE PROPERTY .....	23
RESET_DEVICE COMMAND.....	24
<b>SECTION 5. DEMO PROGRAM</b> .....	<b>25</b>
INSTALLATION.....	25
OPERATION.....	25
SOURCE CODE .....	26

## FIGURES AND TABLES

FIGURE 1-1. USB SWIPE READER .....	vi
TABLE 1-1. SPECIFICATIONS.....	3
FIGURE 1-2. DIMENSIONS.....	4
FIGURE 2-1. READER CABLE AND CONNECTOR.....	5
TABLE 2-1. 4-PIN CONNECTOR .....	5
FIGURE 2-2. MOUNTING HOLE DIMENSIONS FOR SURFACE .....	7

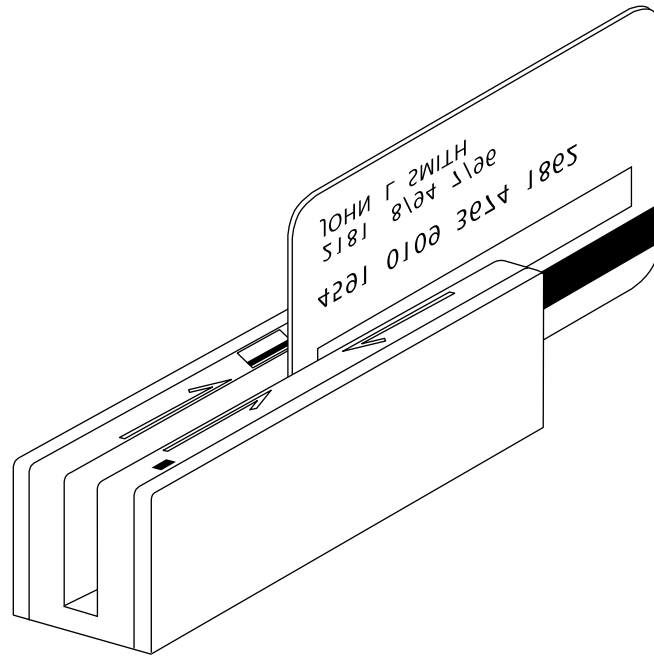

**Figure 1-1. USB Swipe Reader**

## SECTION 1. FEATURES AND SPECIFICATIONS

The USB (Universal Serial Bus) HID (Human Interface Device) Swipe Reader is a compact magnetic stripe card reader that conforms to ISO standards. The Reader is compatible with any device with a host USB interface. A card is read by sliding it, stripe down and facing the LED side, through the slot either forward or backward.

A LED (Light Emitting Diode) indicator on the Reader panel provides the operator with continuous status of the Reader operations.

The reader conforms to the USB HID Class specification Version 1.1. This allows host applications designed for most versions of Windows to easily communicate to the device using standard Windows API calls that communicate to the device through the HID driver that comes with Windows.

Unlike HID keyboard emulation readers, this device does NOT use keyboard emulation. It behaves like a vendor-defined HID device so that a direct communication path can be established between the Host application and the device without interference such as keystrokes from other HID devices. (For information on the USB KB Emulation Reader, refer to Technical Manual 99875206.)

### FEATURES

Major features of the Swipe Reader are as follows:

- Powered through the USB – no external power supply required
- Hardware Compatible with PC or any computer or terminal with a USB interface
- Bi-directional card reading
- Reads encoded data that meets ANSI/ISO/AAMVA standards and others such as ISO track 1 format on track 2 or 3.
- Reads up to three tracks of card data
- LED for status
- Compatible with USB specification Revision 1.1
- Compatible with HID specification Version 1.1
- Can use standard Windows HID driver for communications. No third part device driver is required.
- Programmable USB serial number descriptor
- Programmable USB Interrupt In Endpoint polling interval
- Non-volatile memory for configuration storage
- Built-in 6 foot USB cable
- Ability to convert to Keyboard Emulation mode of operation (new in June 2005)

*Note*

New features have been added to the USB HID Swipe Reader. The following commands were added to most readers that are shipped after June 1, 2005:

MAX\_PACKET\_SIZE PROPERTY  
TRACK\_ID\_ENABLE PROPERTY  
INTERFACE\_TYPE PROPERTY  
RESET\_DEVICE COMMAND

In order to determine if these features are available, request the SOFTWARE\_ID property. If the software ID string shows “21042804xxx”, the new features are NOT available. If the software string shows “21042812xxx”, then these new features are supported.

**HARDWARE CONFIGURATIONS**

The hardware configurations are as follows:

<b>Part Number</b>	<b>Tracks</b>	<b>Color</b>	<b>Cable</b>
21040101	TK 1,2,3	Pearl White	6' USB-A
21040102	TK 1,2,3	Black	6' USB-A
21040103	TK 1,2	Pearl White	6' USB-A
21040104	TK 1,2	Black	6' USB-A
21040113	TK 1,2,3	Black	6' USB-A (Special)
21040114	TK 1,2	Pearl White	6' Black, USB-A
21040119	TK 1,2,3	No enclosure	11" 5 Pin Molex
21040139	TK 1,2,3	No enclosure	21" 5 Pin Molex
21040143	TK 1,2,3	Black	170mm USB-A

**ACCESSORIES**

The accessories are as follows:

<b>Part Number</b>	<b>Description</b>
21042806	USB MSR Demo Program with Source Code (Diskette)
99510026	USB MSR Demo Program with Source Code (WEB)

**REFERENCE DOCUMENTS**

MagTek *USB KB Swipe Reader, Technical Reference Manual* (99875206)

Axelson, Jan. *USB Complete, Everything You Need to Develop Custom USB Peripherals*, 1999. Lakeview Research, 2209 Winnebago St., Madison WI 53704, 396pp., <http://www.lvr.com>.

*USB Human Interface Device (HID) Class Specification Version 1.1.*

*USB (Universal Serial Bus) Specification, Version 1.1*, Copyright© 1998 by Compaq Computer Corporation, Intel Corporation, Microsoft Corporation, NEC Corporation.

USB Implementers Forum, Inc., [www.usb.org](http://www.usb.org).

**SPECIFICATIONS**

Table 1-1 lists the specifications for the USB Swipe Reader. Figure 1-2 shows the dimensions for the standard product.

**Table 1-1. Specifications**

Reference Standards	ISO 7810 and ISO 7811/AAMVA*
Power Input	5V From USB bus
Recording Method	Two-frequency coherent phase (F2F)
Message Format	ASCII
Card Speed	3 to 60 ips (7.62 – 152.4 cm/s)

**ELECTRICAL**

Current	
Normal Mode	15 mA
Suspend Mode	200 uA

**MECHANICAL**

Size	
Length	3.94" (100.0mm)
Width	1.28" (32.5mm)
Height	1.23" (31.3mm)
Weight	4.5 oz. (127.57 g)
Cable length	6 ft. (1.8m)
Connector	USB Type A plug

**ENVIRONMENTAL**

Temperature	
Operating	-40 °C to 70 °C (-40 °F to 158 °F)
Storage	-40 °C to 70 °C (-40 °F to 158 °F)
Humidity	
Operating	10% to 90% noncondensing
Storage	10% to 90% noncondensing
Altitude	
Operating	0-10,000 ft. (0-3048 m.)
Storage	0-50,000 ft. (0-15240 m.)

\* ISO (International Standards Organization) and AAMVA (American Association of Motor Vehicle Administrators).

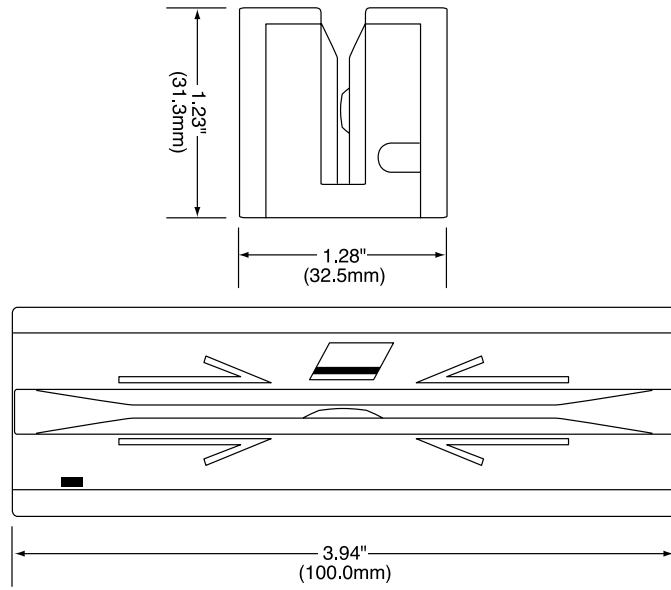

**Figure 1-2. Dimensions**

## SECTION 2. INSTALLATION

This section describes the cable connection, the Windows Plug and Play Setup, and the physical mounting of the unit.

### USB CONNECTION

Connect the USB cable to a USB port on the host. The Reader, LED Indicator, and pin numbers for the 4-pin connector are shown in Figure 2-1.

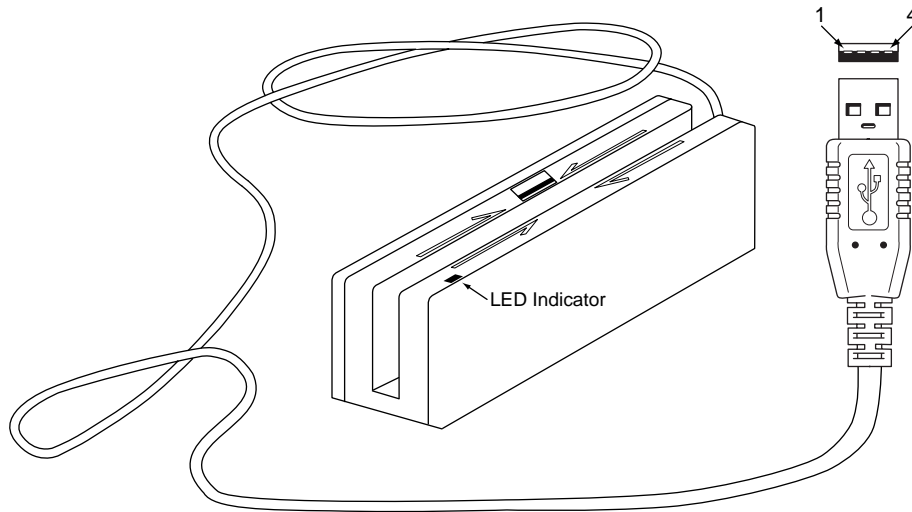

**Figure 2-1. Reader Cable and Connector**

Pin numbers and signal descriptions for the cable shown in the illustration are listed in Table 2-1.

**Table 2-1. 4-Pin Connector**

Pin Number	Signal	Cable Color
1	VBUS	Red
2	-Data	White
3	+Data	Green
4	Ground	Black

## WINDOWS PLUG AND PLAY SETUP

On hosts with the Windows operating system, the first time the device is plugged into a specific USB port, Windows will pop up a dialog box, which will guide you through the process of installing a device driver for the device. After this process is completed once, Windows will no longer request this process as long as the device is plugged into the same USB port. The device driver that Windows will install for this device is the driver used for HID devices and it is part of the Windows operating system. When the dialog box pops up, follow the instructions given in the dialog box. Sometimes Windows will find all the files it needs on its own without giving any prompts. Other times Windows will need to know the location of the files it needs. If Windows prompts for the file locations, insert the CD that was used to install Windows on your PC and point Windows to the root directory of the CD. Windows should find all the files it needs there.

## MOUNTING

The Reader may be mounted with screws or fastening tape as described below.

### *Caution*

*The Reader should be mounted such that the bottom (mounting side) is not exposed to the user. This is because the mounting side of the reader may be susceptible to electrostatic discharge.*

1. The Reader can be mounted on a surface in various ways:
  - By two screws through the surface attached to the bottom of the unit and running the cable on the top of the surface
  - By two screws through the surface attached to the bottom of the unit and by drilling a hole in the surface for the cable and running the cable through the hole
  - By attaching the unit to the surface with fastening tape and running the cable on the top of the surface

### *Note*

*The two mounting inserts are 3mm diameter, 0.5mm pitch, 6.4mm deep. The length of the screws used depends on the mounting surface thickness and the thickness of washers (if used).*

The mounting dimensions are shown in Figure 2-2. Determine the method of mounting required.

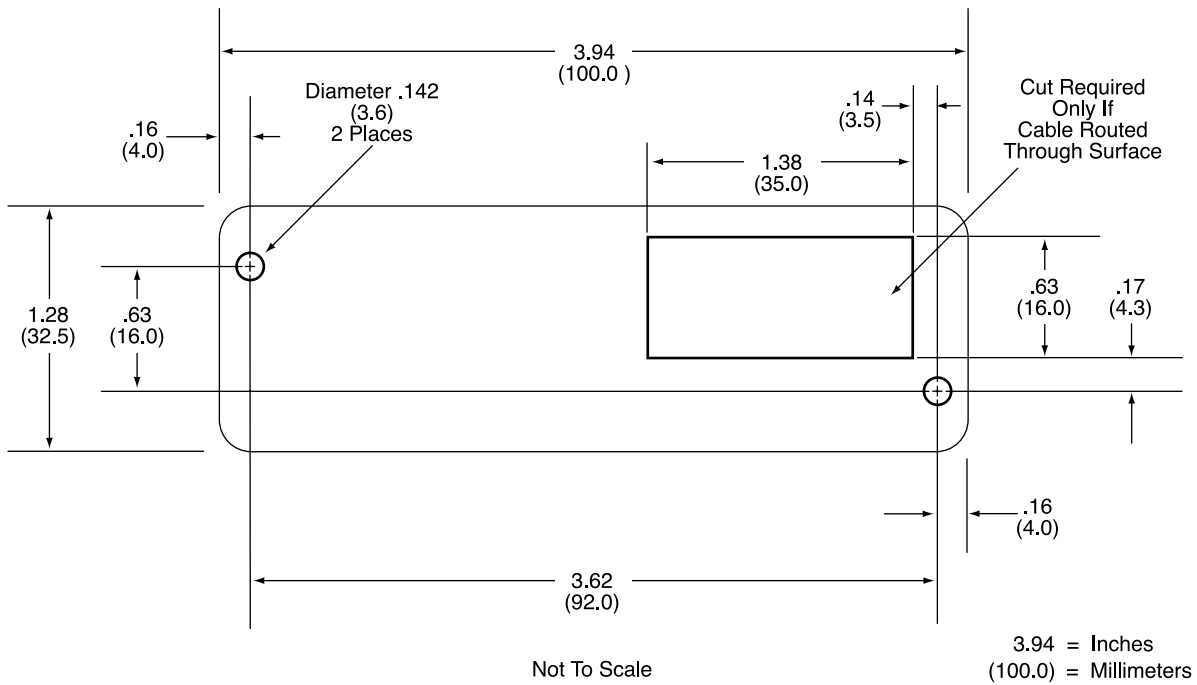

**Figure 2-2. Mounting Hole Dimensions for Surface**

2. Ensure the Reader is positioned on a flat, accessible surface with at least 4 inches clearance on either end for room to swipe a card. Orient the Reader so the side with the LED is facing the direction of intended use.

If fastening tape is to be used, clean the area that the Reader will be mounted on with isopropyl alcohol. Remove the adhesive protective cover on the fastening tape, and position the Reader and push down firmly.

3. Mount the Reader.



## **SECTION 3. OPERATION**

This section describes the LED Indicator and Card Read.

### **LED INDICATOR**

The LED indicator will be either off, red, or green. When the device is not powered, the LED will be off. When the device is first plugged in, the LED will be red. As soon as the device is plugged in, the host will try to enumerate the device. Once the device is enumerated the LED will turn green indicating that the device is ready for use. When a card is being swiped, the LED will turn off temporarily until the swipe is completed. If there are no errors after decoding the card data then the LED will turn green. If there are any errors after decoding the card data, the LED will turn red for approximately two seconds to indicate that an error occurred and then turn green. Anytime the host puts the device into suspend mode, the LED will turn off. Once the host takes the device out of suspend mode, the LED will return to the state it was in prior to entering suspend mode.

### **CARD READ**

A card may be swiped through the Reader slot when the LED is green. The magnetic stripe must face toward the front (the side with the LED) and may be swiped in either direction. If there is data encoded on the card, the device will attempt to decode the data and then send the results to the host via a USB HID input report. After the results are sent to the host, the device will be ready to read the next card.



## SECTION 4. USB COMMUNICATIONS

This device conforms to the USB specification revision 1.1. This device also conforms with the Human Interface Device (HID) class specification version 1.1. The device communicates to the host as a vendor-defined HID device. The details about how the card data and commands are structured into HID reports follow later in this section. The latest versions of the Windows operating systems come with a standard Windows USB HID driver. Windows applications that communicate to this device can be easily developed. These applications can communicate to the device using standard windows API calls that communicate to the device using the standard Windows USB HID driver. These applications can be easily developed using compilers such as Microsoft's Visual Basic or Visual C++. A demonstration program and its source code, written in Visual Basic, that communicates with this device is available. This demo program can be used to test the device and it can be used as a guide for developing other applications. More details about the demo program follow later in this document.

It is recommended that application software developers become familiar with the HID specification the USB specification before attempting to communicate with this device. This document assumes that the reader is familiar with these specifications. These specifications can be downloaded free from [www.usb.org](http://www.usb.org).

This is a full speed USB device. This device has a number of programmable configuration properties. These properties are stored in non-volatile memory. These properties can be configured at the factory or by the end user. The device has an adjustable endpoint descriptor polling interval value that can be set to any value in the range of 1ms to 255ms. This property can be used to speed up or slow down the card data transfer rate. The device also has an adjustable serial number descriptor. More details about these properties can be found later in this document in the command section.

The device will go into suspend mode when directed to do so by the host. The device will wakeup from suspend mode when directed to do so by the host. The device does not support remote wakeup.

This device is powered from the USB bus. Its vendor ID is 0x0801 and its product ID is 0x0002.

### HID USAGES

HID devices send data in reports. Elements of data in a report are identified by unique identifiers called usages. The structure of the device's reports and the device's capabilities are reported to the host in a report descriptor. The host usually gets the report descriptor only once, right after the device is plugged in. The report descriptor usages identify the devices capabilities and report structures. For example, a device could be identified as a keyboard by analyzing the device's report descriptor. Usages are four byte integers. The most significant two bytes are called the usage page and the least significant two bytes are called usage IDs. Usages that are related can share a common usage page. Usages can be standardized or they can be vendor defined. Standardized usages such as usages for mice and keyboards can be found in the HID Usage Tables document and can be downloaded free at [www.usb.org](http://www.usb.org). Vendor-defined usages must have a usage page in the range 0xff00 – 0xffff. All usages for this device use vendor-defined magnetic stripe reader usage page 0xff00. The usage IDs for this device are defined in the

following table. The usage types are also listed. These usage types are defined in the HID Usage Tables document.

Magnetic Stripe Reader usage page 0xff00:

Usage ID (Hex)	Usage Name	Usage Type	Report Type
1	Decoding reader device	Collection	None
20	Track 1 decode status	Data	Input
21	Track 2 decode status	Data	Input
22	Track 3 decode status	Data	Input
28	Track 1 data length	Data	Input
29	Track 2 data length	Data	Input
2A	Track 3 data length	Data	Input
30	Track 1 data	Data	Input
31	Track 2 data	Data	Input
32	Track 3 data	Data	Input
38	Card encode type	Data	Input
20	Command message	Data	Feature

## REPORT DESCRIPTOR

The HID report descriptor is structured as follows:

Item	Value (Hex)
Usage Page (Magnetic Stripe Reader)	06 00 FF
Usage (Decoding reader device)	09 01
Collection (Application)	A1 01
Logical Minimum (0)	15 00
Logical Maximum (255)	26 FF 00
Report Size (8)	75 08
Usage (Track 1 decode status)	09 20
Usage (Track 2 decode status)	09 21
Usage (Track 3 decode status)	09 22
Usage (Track 1 data length)	09 28
Usage (Track 2 data length)	09 29
Usage (Track 3 data length)	09 2A
Usage (Card encode type)	09 38
Report Count (7)	95 07
Input (Data, Variable, Absolute, Bit Field)	81 02
Usage (Track 1 data)	09 30
Report Count (110)	95 6E
Input (Data, Variable, Absolute, Buffered Bytes)	82 02 01
Usage (Track 2 data)	09 31
Report Count (110)	95 6E
Input (Data, Variable, Absolute, Buffered Bytes)	82 02 01
Usage (Track 3 data)	09 32

Item	Value (Hex)
Report Count (110)	95 6E
Input (Data, Variable, Absolute, Buffered Bytes)	82 02 01
Usage (Command message)	09 20
Report Count (24)	95 18
Feature (Data, Variable, Absolute, Buffered Bytes)	B2 02 01
End Collection	C0

## CARD DATA

Card data is only sent to the host on the Interrupt In pipe using an Input Report. The device will send only one Input Report per card swipe. If the host requests data from the device when no data is available, the device will send a Nak to the host to indicate that it has nothing to send. When a card is swiped, the Input Report will be sent even if the data is not decodable. The following table shows how the input report is structured.

Offset	Usage Name
0	Track 1 decode status
1	Track 2 decode status
2	Track 3 decode status
3	Track 1 data length
4	Track 2 data length
5	Track 3 data length
6	Card encode type
7 – 116	Track 1 data
117 – 226	Track 2 data
227 - 336	Track 3 data

## TRACK 1 DECODE STATUS

Bits	7-1	0
Value	Reserved	Error

This is a one-byte value, which indicates the status of decoding track 1. Bit position zero indicates if there was an error decoding track 1 if the bit is set to one. If it is zero, then no error occurred. If a track has data on it that is not noise, and it is not decodable, then a decode error is indicated. If a decode error is indicated, the corresponding track data length value for the track that has the error will be set to zero and no valid track data will be supplied.

### TRACK 2 DECODE STATUS

Bits	7-1	0
Value	Reserved	Error

This is a one-byte value, which indicates the status of decoding track 2. Bit position zero indicates if there was an error decoding track 2 if this bit is set to one. If it is zero, then no error occurred. If a track has data on it that is not noise, and it is not decodable, then a decode error is indicated. If a decode error is indicated, the corresponding track data length value for the track that has the error will be set to zero and no valid track data will be supplied.

### TRACK 3 DECODE STATUS

Bits	7-1	0
Value	Reserved	Error

This is a one-byte value, which indicates the status of decoding track 3. Bit position zero indicates if there was an error decoding track 3 if this bit is set to one. If it is zero, then no error occurred. If a track has data on it that is not noise, and it is not decodable, then a decode error is indicated. If a decode error is indicated, the corresponding track data length value for the track that has the error will be set to zero and no valid track data will be supplied.

### TRACK 1 DATA LENGTH

This one-byte value indicates how many bytes of decoded card data are in the track 1 data field. This value will be zero if there was no data on the track or if there was an error decoding the track.

### TRACK 2 DATA LENGTH

This one-byte value indicates how many bytes of decoded card data are in the track 2 data field. This value will be zero if there was no data on the track or if there was an error decoding the track.

### TRACK 3 DATA LENGTH

This one-byte value indicates how many bytes of decoded card data are in the track 3 data field. This value will be zero if there was no data on the track or if there was an error decoding the track.

## CARD ENCODE TYPE

This one-byte value indicates the type of encoding that was found on the card. The following table defines the possible values.

Value	Encode Type	Description
0	ISO/ABA	ISO/ABA encode format
1	AAMVA	AAMVA encode format
2	CADL	CADL encode format. Note that (after the June 2005 update) this reader can only read track 2 for this format. It cannot read tracks 1 and 3. However, this format is obsolete. There should no longer be any cards in circulation that use this format. California is now using the AAMVA format.
3	Blank	The card is blank.
4	Other	The card has a non-standard encode format. For example, ISO/ABA track 1 format on track 2.
5	Undetermined	The card encode type could not be determined because no tracks could be decoded.
6	None	No decode has occurred. This type occurs if no magnetic stripe data has been acquired since the data has been cleared or since the device was powered on. This device only sends an Input report when a card has been swiped so this value will never occur.

## TRACK DATA

If decodable track data exists for a given track, it is located in the track data field that corresponds to the track number. The length of each track data field is fixed at 110 bytes, but the length of valid data in each field is determined by the track data length field that corresponds to the track number. Track data located in positions greater than the track data length field indicates are undefined and should be ignored. The HID specification requires that reports be fixed in size, but the number of bytes encoded on a card may vary. Therefore, the Input Report always contains the maximum amount of bytes that can be encoded on the card and the number of valid bytes in each track is indicated by the track data length field. The track data is decoded and converted to ASCII. The track data includes all data starting with the start sentinel and ending with the end sentinel.

### TRACK 1 DATA

This field contains the decoded track data for track 1.

### TRACK 2 DATA

This field contains the decoded track data for track 2.

### TRACK 3 DATA

This field contains the decoded track data for track 3.

## COMMANDS

Most host applications do not need to send commands to the device. Most host applications only need to obtain card data from the device as described previously in this section. This section of the manual can be ignored by anyone who does not need to send commands to the device.

Command requests and responses are sent to and received from the device using feature reports. Command requests are sent to the device using the HID class specific request Set\_Report. The response to a command is retrieved from the device using the HID class specific request Get\_Report. These requests are sent over the default control pipe. When a command request is sent, the device will Nak the Status stage of the Set\_Report request until the command is completed. This insures that, as soon as the Set\_Report request is completed, the Get\_Report request can be sent to get the command response. The usage ID for the command message was shown previously in the Usage Table.

The following table shows how the feature report is structured for command requests:

Offset	Field Name
0	Command Number
1	Data Length
2 – 23	Data

The following table shows how the feature report is structured for command responses.

Offset	Field Name
0	Result Code
1	Data Length
2 – 23	Data

## COMMAND NUMBER

This one-byte field contains the value of the requested command number. The following table lists all the existing commands.

Value	Command Number	Description
0	GET_PROPERTY	Gets a property from the device
1	SET_PROPERTY	Sets a property in the device
2	RESET_DEVICE	Resets the device

## DATA LENGTH

This one-byte field contains the length of the valid data contained in the Data field.

## DATA

This multi-byte field contains command data if any. Note that the length of this field is fixed at 22 bytes. Valid data should be placed in the field starting at offset 2. Any remaining data after the valid data should be set to zero. This entire field must always be set even if there is no valid data. The HID specification requires that Reports be fixed in length. Command data may vary in length. Therefore, the Report should be filled with zeros after the valid data.

## RESULT CODE

This one-byte field contains the value of the result code. There are two types of result codes: generic result codes and command-specific result codes. Generic result codes always have the most significant bit set to zero. Generic result codes have the same meaning for all commands and can be used by any command. Command-specific result codes always have the most significant bit set to one. Command-specific result codes are defined by the command that uses them. The same code can have different meanings for different commands. Command-specific result codes are defined in the documentation for the command that uses them. Generic result codes are defined in the following table.

Value	Result Code	Description
0	SUCCESS	The command completed successfully.
1	FAILURE	The command failed.
2	BAD_PARAMETER	The command failed due to a bad parameter or command syntax error.

## GET AND SET PROPERTY COMMANDS

The Get Property command gets a property from the device. The Get Property command number is 0.

The Set Property command sets a property in the device. The Set Property command number is 1.

The Get and Set Property command data fields for the requests and responses are structured as follows:

Get Property Request Data:

Data Offset	Value
0	Property ID

Get Property Response Data:

Data Offset	Value
0 – n	Property Value

Set Property Request Data:

Data Offset	Value
0	Property ID
1 – n	Property Value

Set Property Response Data:

None

The result codes for the Get and Set Property commands can be any of the codes list in the generic result code table.

Property ID is a one-byte field that contains a value that identifies the property. The following table lists all the current property ID values:

Value	Property ID	Description
0	SOFTWARE_ID	The device's software identifier
1	SERIAL_NUM	The device's serial number
2	POLLING_INTERVAL	The interrupt pipe's polling interval
3	MAX_PACKET_SIZE	The interrupt pipe's packet size
4	TRACK_ID_ENABLE	Allows tracks to be disabled
16	INTERFACE_TYPE	Type of USB interface

The Property Value is a multiple-byte field that contains the value of the property. The number of bytes in this field depends on the type of property and the length of the property. The following table lists all of the property types and describes them.

Property Type	Description
Byte	This is a one-byte value. The valid values depend on the property.
String	This is a multiple-byte ASCII string. Its length can be zero to a maximum length that depends on the property. The value and length of the string does not include a terminating NUL character.

### **SOFTWARE\_ID PROPERTY**

Property ID: 0  
 Property Type: String  
 Length: Fixed at 11 bytes  
 Get Property: Yes  
 Set Property: No  
 Description: This is an 11-byte read only property that identifies the software part number and version for the device. The first 8 bytes represent the part number and the last 3 bytes represent the version. For example this string might be "21042812D01". Examples follow:

Example Get SOFTWARE\_ID property Request (Hex):

Cmd Num	Data Len	Prp ID
00	01	00

Example Get SOFTWARE\_ID property Response (Hex):

Result Code	Data Len	Prp Value
00	01	32 31 30 34 32 38 31 32 44 30 31

**SERIAL\_NUM PROPERTY**

Property ID:	1
Property Type:	String
Length:	0 – 15 bytes
Get Property:	Yes
Set Property:	Yes
Default Value:	The default value is no string with a length of zero.
Description:	The value is an ASCII string that represents the device's serial number. This string can be 0 – 15 bytes long. The value of this property, if any, will be sent to the host when the host requests the USB string descriptor.

This property is stored in non-volatile memory, so it will persist when the unit is power cycled. When this property is changed, the unit must be reset (see Command Number 2) or power cycled to have these changes take effect.

Example Set SERIAL\_NUM property Request (Hex):

Cmd Num	Data Len	Prp ID	Prp Value
01	04	01	31 32 33

Example Set SERIAL\_NUM property Response (Hex):

Result Code	Data Len	Data
00	00	

Example Get SERIAL\_NUM property Request (Hex):

Cmd Num	Data Len	Prp ID
00	01	01

Example Get SERIAL\_NUM property Response (Hex):

Result Code	Data Len	Prp Value
00	03	31 32 33

## POLLING\_INTERVAL PROPERTY

Property ID: 2  
 Property Type: Byte  
 Length: 1 byte  
 Get Property: Yes  
 Set Property: Yes  
 Default Value: 10  
 Description: The value is a byte that represents the devices polling interval for the Interrupt In Endpoint. The value can be set in the range of 1 – 255 and has units of milliseconds. The polling interval tells the host how often to poll the device for card data packets. For example, if the polling interval is set to 10, the host will poll the device for card data packets every 10ms. This property can be used to speed up or slow down the time it takes to send card data to the host. The trade-off is that speeding up the card data transfer rate increases the USB bus bandwidth used by the device, and slowing down the card data transfer rate decreases the USB bus bandwidth used by the device. The value of this property, if any, will be sent to the host when the host requests the device’s USB endpoint descriptor.

This property is stored in non-volatile memory, so it will persist when the unit is power cycled. When this property is changed, the unit must be reset (see Command Number 2) or power cycled to have these changes take effect.

Example Set POLLING\_INTERVAL property Request (Hex):

Cmd Num	Data Len	Prp ID	Prp Value
01	02	02	0A

Example Set POLLING\_INTERVAL property Response (Hex):

Result Code	Data Len	Data
00	00	

Example Get POLLING\_INTERVAL property Request (Hex):

Cmd Num	Data Len	Prp ID
00	01	02

Example Get POLLING\_INTERVAL property Response (Hex):

Result Code	Data Len	Prp Value
00	01	0A

**MAX\_PACKET\_SIZE PROPERTY**

Property ID: 3  
 Property Type: Byte  
 Length: 1 byte  
 Get Property: Yes  
 Set Property: Yes  
 Default Value: 8  
 Description: The value is a byte that represents the devices maximum packet size for the Interrupt In Endpoint. The value can be set in the range of 1 – 64 and has units of bytes. The maximum packet size tells the host the maximum size of the Interrupt In Endpoint packets. For example, if the maximum packet size is set to 8, the device will send HID reports in multiple packets of 8 bytes each or less for the last packet of the report. This property can be used to speed up or slow down the time it takes to send card data to the host. Larger packet sizes speed up communications and smaller packet sizes slow down communications. The trade-off is that speeding up the card data transfer rate increases the USB bus bandwidth used by the device, and slowing down the card data transfer rate decreases the USB bus bandwidth used by the device. The value of this property will be sent to the host when the host requests the device's USB endpoint descriptor.

This property is stored in non-volatile memory, so it will persist when the unit is power cycled. When this property is changed, the unit must be reset (see Command Number 2) or power cycled to have these changes take effect.

Example Set MAX\_PACKET\_SIZE property Request (Hex):

Cmd Num	Data Len	Prp ID	Prp Value
01	02	03	08

Example Set MAX\_PACKET\_SIZE property Response (Hex):

Result Code	Data Len	Data
00	00	

Example Get MAX\_PACKET\_SIZE property Request (Hex):

Cmd Num	Data Len	Prp ID
00	01	03

Example Get MAX\_PACKET\_SIZE property Response (Hex):

Result Code	Data Len	Prp Value
00	01	08

## TRACK\_ID\_ENABLE PROPERTY

Property ID: 4  
 Property Type: Byte  
 Length: 1 byte  
 Get Property: Yes  
 Set Property: Yes  
 Default Value: 95 (hex)  
 Description: This property is defined as follows:

id	0	T <sub>3</sub>	T <sub>3</sub>	T <sub>2</sub>	T <sub>2</sub>	T <sub>1</sub>	T <sub>1</sub>
----	---	----------------	----------------	----------------	----------------	----------------	----------------

Id 0 – Decodes standard ISO/ABA cards only  
 1 – Decodes AAMV and 7-bit cards also

T<sub>#</sub> 00 – Track Disabled  
 01 – Track Enabled  
 10 – Track Enabled/Required (Error if blank)

This property is stored in non-volatile memory, so it will persist when the unit is power cycled. When this property is changed, the unit must be reset (see Command Number 2) or power cycled to have these changes take effect.

Example Set TRACK\_ID\_ENABLE property Request (Hex):

Cmd Num	Data Len	Prp ID	Prp Value
01	02	04	95

Example Set TRACK\_ID\_ENABLE property Response (Hex):

Result Code	Data Len	Data
00	00	

Example Get TRACK\_ID\_ENABLE property Request (Hex):

Cmd Num	Data Len	Prp ID
00	01	04

Example Get TRACK\_ID\_ENABLE property Response (Hex):

Result Code	Data Len	Prp Value
00	01	95

**INTERFACE\_TYPE PROPERTY**

Property ID: 16 (10 hex)  
 Property Type: Byte  
 Length: 1 byte  
 Get Property: Yes  
 Set Property: Yes  
 Default Value: 0 (HID)  
 Description: The value is a byte that represents the devices interface type. The value can be set to 0 for the HID interface or to 1 for the keyboard emulation interface. When the value is set to 0 (HID) the device will behave as described in the HID manual. When the value is set to 1 (keyboard emulation) the device will behave as described in the keyboard emulation manual. This property should be the first property changed because it affects which other properties are available. After this property is changed, the device should be power cycled before changing any other properties.

This property is stored in non-volatile memory, so it will persist when the unit is power cycled. When this property is changed, the unit must be reset (see Command Number 2) or power cycled to have these changes take effect.

Example Set INTERFACE\_TYPE property Request (Hex):

Cmd Num	Data Len	Prp ID	Prp Value
01	02	10	01

Example Set INTERFACE\_TYPE property Response (Hex):

Result Code	Data Len	Data
00	00	

Example Get INTERFACE\_TYPE property Request (Hex):

Cmd Num	Data Len	Prp ID
00	01	10

Example Get INTERFACE\_TYPE property Response (Hex):

Result Code	Data Len	Prp Value
00	01	00

## RESET\_DEVICE COMMAND

Command number: 2

Description: This command is used to reset the device. This command can be used to make previously changed properties take affect without having to unplug and then plug in the device. When the device resets, it automatically does a USB detach followed by an attach. After the host sends this command to the device it should close the USB port, wait a few seconds for the operating system to handle the device detach followed by the attach and then re-open the USB port before trying to communicate further with the device.

Data structure: No data is sent with this command

Result codes: 0 (success)

Example Request (Hex):

Cmd Num	Data Len	Data
02	00	

Example Response (Hex):

Result Code	Data Len	Data
00	00	

## SECTION 5. DEMO PROGRAM

The demo program, which is written in Visual Basic, can be used to do the following:

- Read cards from the device and view the card data
- Send command requests to the device and view the command responses
- Guide application developers in their application development by providing examples, in source code, of how to properly communicate with the device using the standard Windows APIs

The part numbers for the demo program can be found in this document in Section 1 under Accessories.

### INSTALLATION

To install the demo program, run the setup.exe file and follow the instructions given on the screen.

### OPERATION

To operate the demo program perform the following steps:

- Attach the device into a USB port on the host.
- If this is the first time the device has been plugged into the host, follow the instructions on the screen for installing the Windows HID device driver. This is explained in more detail in the installation section of this document.
- Run the demo program.
- To read cards and view the card data, click on the Read Cards button and swipe a card when prompted to do so.
- When finished reading cards, close the dialog box.
- To send commands to the device, click on the send commands button.
- Enter a command in the Message edit box. All data entered should be in hexadecimal bytes with a space between each byte. Enter the command number followed by the command data if there is any. **The application will automatically calculate and send the command data length for you.** For example, to send the GET\_PROPERTY command for property SOFTWARE\_ID enter 00 00.
- Press Enter or click on Send message to send the command and receive the result.
- The command request and the command result will be displayed in the Communications Dialog edit box.
- The Clear Dialog button clears the Communication Dialog edit box.

## **SOURCE CODE**

Source code is included with the demo program. It can be used as a guide for application development. It is described in detail, with comments, to assist developers. The book *USB Complete* by Jan Axelson is also a good guide for application developers, especially the chapter on Human Interface Device Host Applications (see “Reference Documents” in Section 1).